













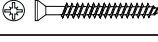

REF	FERRAGENS	QTD
A	 8 x 30 mm	52
B	 10 x 10 mm	30
C	 Parafuso Minifix	04
D	 Tambor Minifix	04
E	 5 x 50 mm	06
F	 4 x 16 mm	08
G	 4 x 14 mm	116
H	 Puxador	04
I	 Cantoneira Plástica	34
J	 Sapata Plástica	04
K	 Corrediça Telescópica	04
L	 Tampa adesiva	15
M	 Perfil H	01

Lista de peças

CÓD	DESCRIÇÃO	QTD	DIMENSÕES
01	Lateral Direita	1	785 x 395 x 15
02	Lateral Esquerda	1	785 x 395 x 15
03	Divisória	1	720 x 395 x 15
04	Tampo	1	800 x 410 x 15
05	Base	1	770 x 395 x 15
06	Prateleiras	3	175 x 395 x 15
07	Frente Gaveta	4	600 x 175 x 15
08	Laterais Gaveta	8	350 x 100 x 15
09	Traseiro Gaveta	4	475 x 100 x 15
10	Rodapé	1	770 x 50 x 15
11	Costas	2	750 x 398 x 3
12	Fundos Gaveta	4	505 x 350 x 3

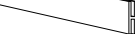
FERRAMENTAS NECESSÁRIAS:

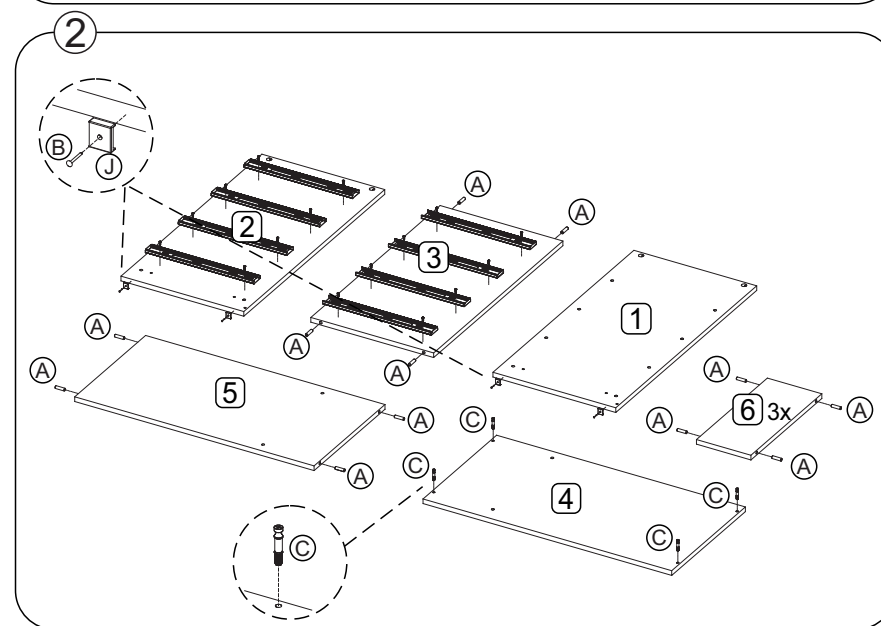
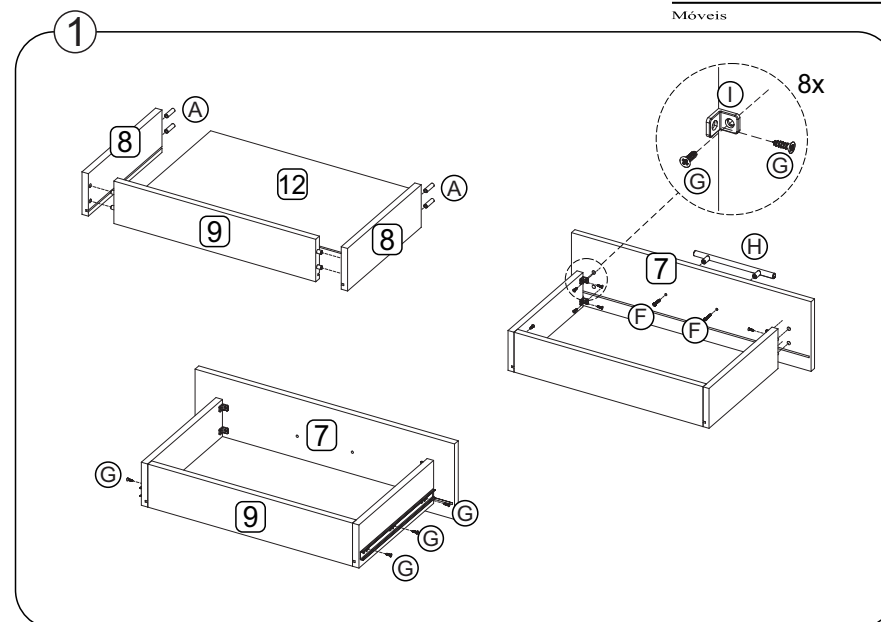

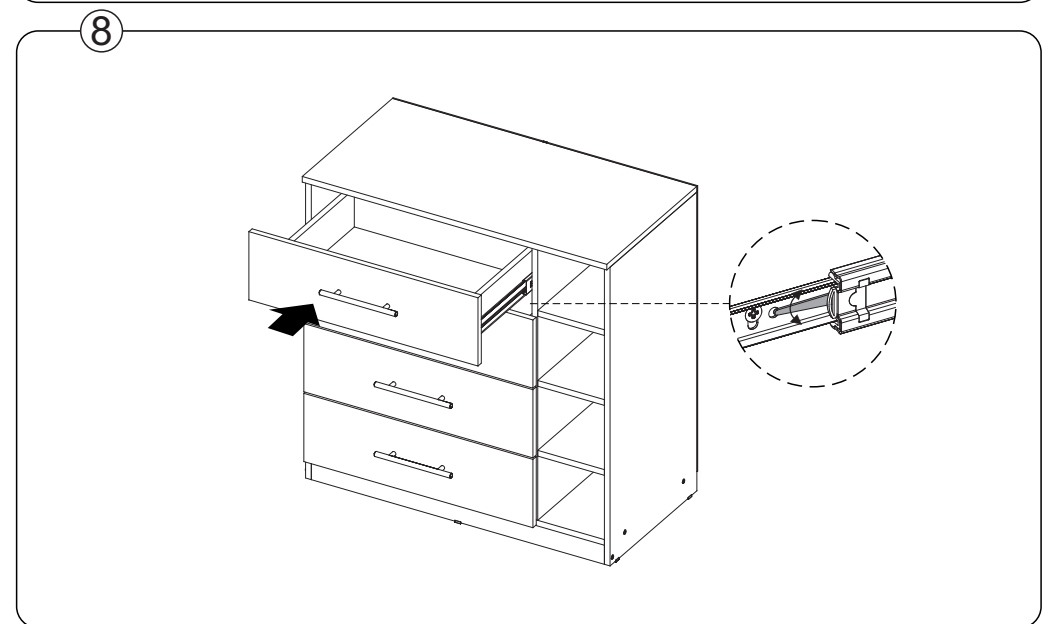
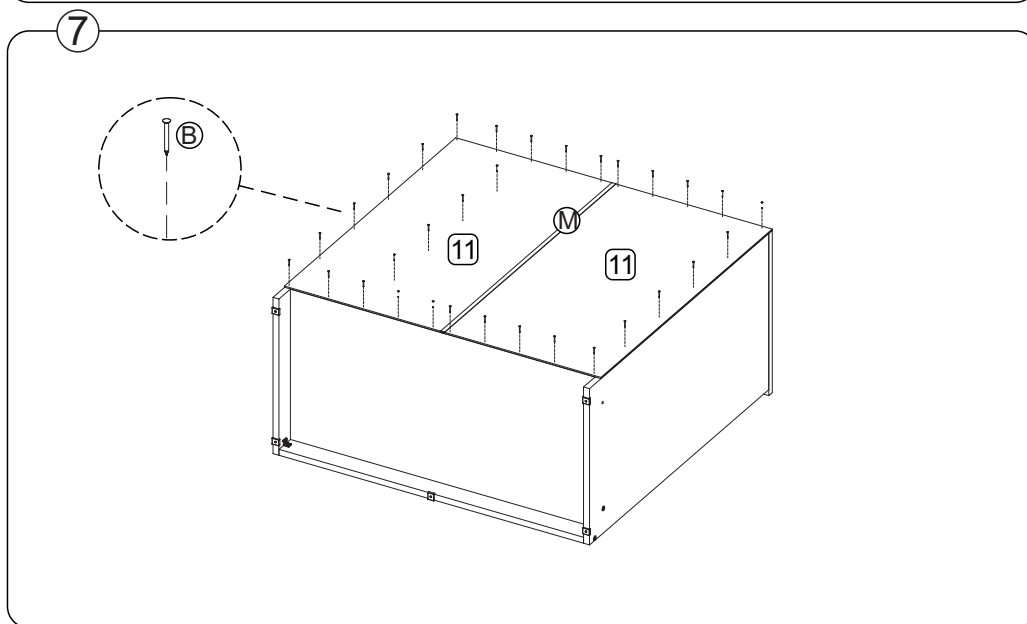
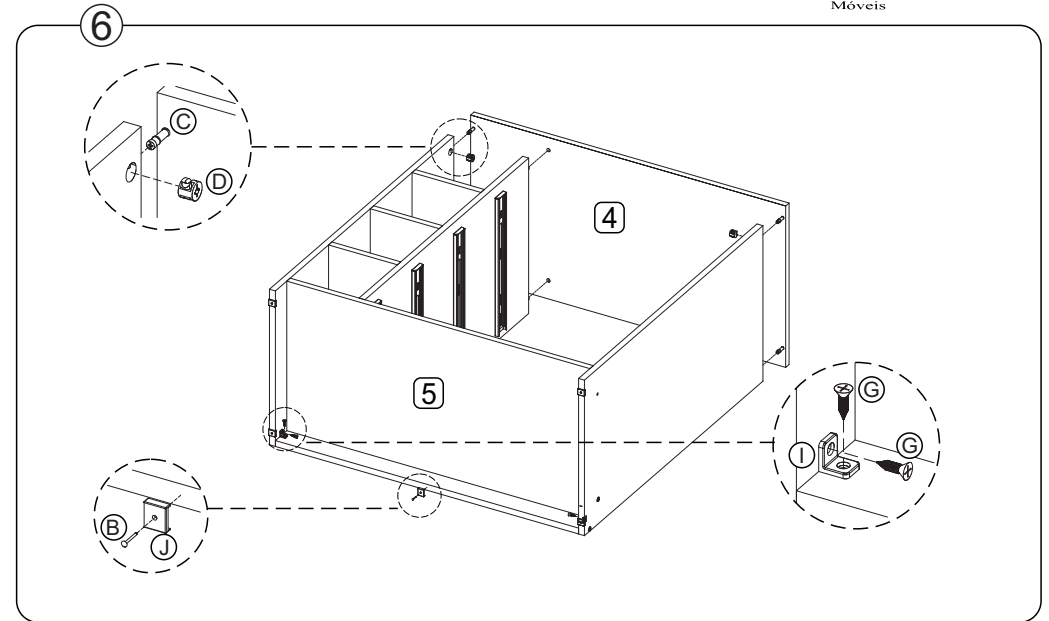
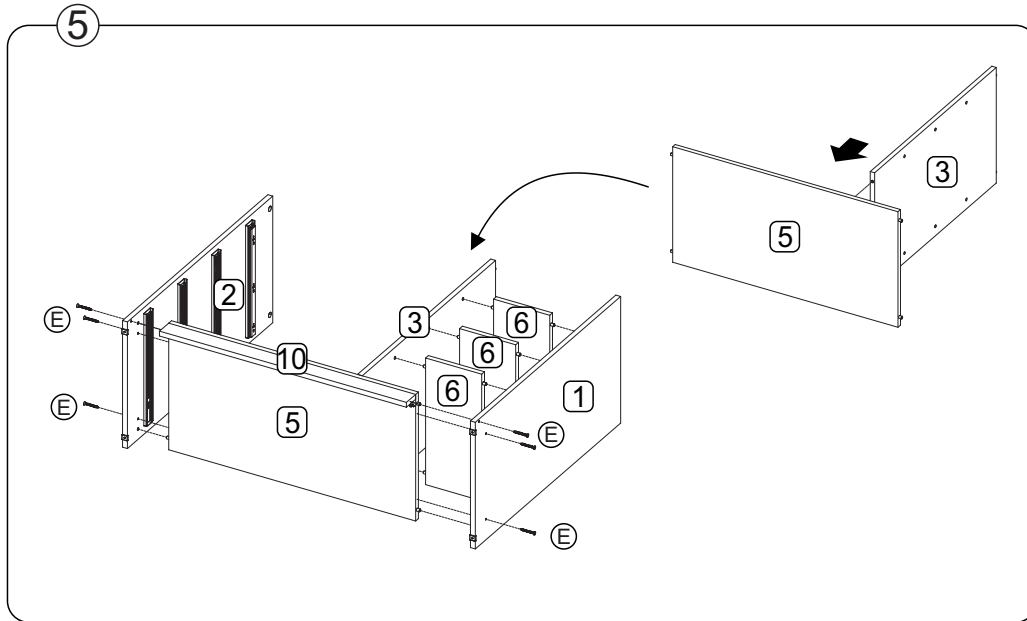

"IMPORTANTE LER COM ATENÇÃO E GUARDAR PARA EVENTUAIS CONSULTAS"